

REVISION RECORD

REV	DESCRIPTION	DATE	APPD

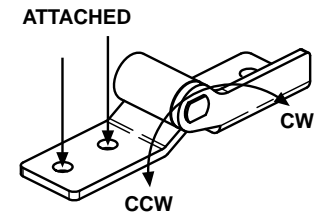
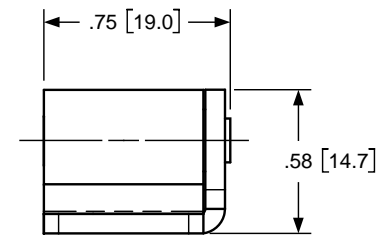
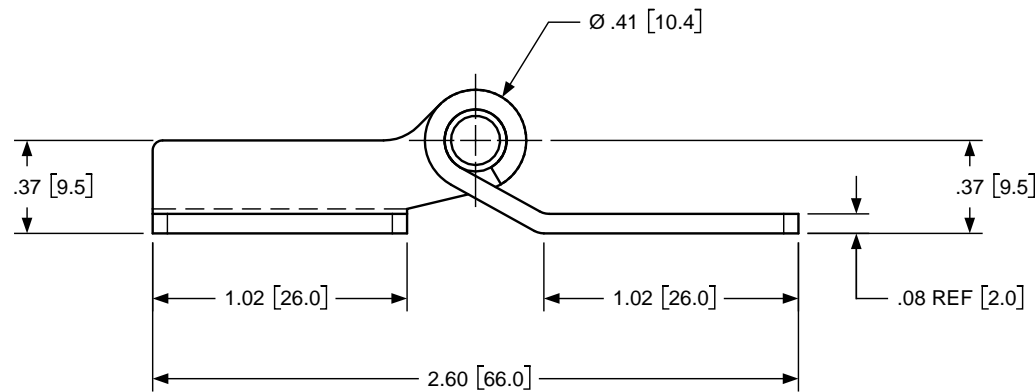
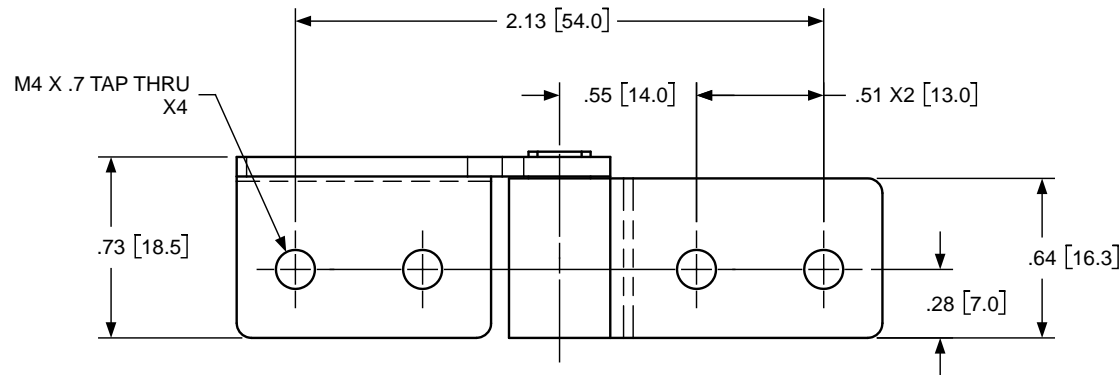

- NOTES:
- HINGE TORQUE: UNBALANCED.
 - CCW TORQUE = 13.0 ± 15% IN.LB.
 - CW TORQUE = LESS THAN CCW TORQUE.
 - FINISH: ELECTROLESS NICKEL.

HANAYA		TITLE HINGE INTERFACE			
ALL INFORMATION ON THIS PRINT ARE PROPRIETARY TO HANAYA, AND SHALL NOT BE USED IN WHOLE OR IN PART WITHOUT HANAYA'S CONSENT.		ENGLISH / METRIC		MATERIAL	
		TOLERANCES		STEEL BAND & SHAFT	
		METRIC	ENGLISH	SIZE	DWG NO
		.X ±.3 MM	.XX ±.015 IN	B	0024-0010-HNG
		.XX ±.13 MM	.XXX ±.005 IN		
		.XXX ±.005 MM	.XXXX ±.0002 IN		
USED ON	REV	ANGLE ± 1°		DRAWN BY	DATE
				SCALE	SHEET 1 OF 1